

DATA SHEET

Company		Date	31/01/2023
Project		Item	
		Ref No.	

SNSM 100-200-30

Horizontal, single stage, radially split, closed-coupled, volute casing type conforming to EN 733 and EU 547/2012

Operating Point Data

Capacity	:	Power at Duty Point	:
Head	:	Frequency	: 50 Hz
Efficiency (%)	:	Voltage	: 380 V
Impeller Diameter	: 185 mm	Motor Power	: 30.00 kW
NPSHr	:	Nominal Speed	: 2975 rpm
Shut Off Head	: 42.8 m		

Liquid Data

Liquid	: Water	Density	: 998.30 kg/m ³
Temperature	: 20 °C	Viscosity	: 1.005 cSt

Pump Data

Design	: Single Stage, End Suction, Monoblock		
Installation	: Horizontal	Direction Of Rotation	: Clockwise from the drive end
Suction Flange	: EN 1092 PN 16-DN 125	Impeller Type	: Radial impeller
Discharge Flange	: EN 1092 PN 16-DN 100	Type of Shaft Sealing	: Mechanical Seal
Pressure rating	: PN10		

Minimum Efficiency Index (MEI) >= 0,4

Materials

Volute Casing	0.6025 / GG25 / EN-GJL-250 / ASTM A48 Class 40B
Casing Cover	0.6025 / GG25 / EN-GJL-250 / ASTM A48 Class 40B
Impeller	0.6025 / GG25 / EN-GJL-250 / ASTM A48 Class 40B
Shaft	1.4021 / X20Cr13 / ASTM A276 Type 420
Mechanical Seal Sleeve	1.4021 / X20Cr13 / ASTM A276 Type 420
Motor Pedestal	0.6025 / GG25 / EN-GJL-250 / ASTM A48 Class 40B

Operating Point Data

Company		Date	31/01/2023
Project		Item	
		Ref No.	

SNSM 100-200-30

Horizontal, single stage, radially split, closed-coupled, volute casing type conforming to EN 733 and EU 547/2012

Capacity:		NPSHr:	
Head:		Motor Power:	30.00 kW
Efficiency (%):		Nominal Speed:	2975 rpm
Power at Duty Point:		Frequency:	50 Hz
Viscosity: 1.005 cSt		Density:	998.30 kg/m ³

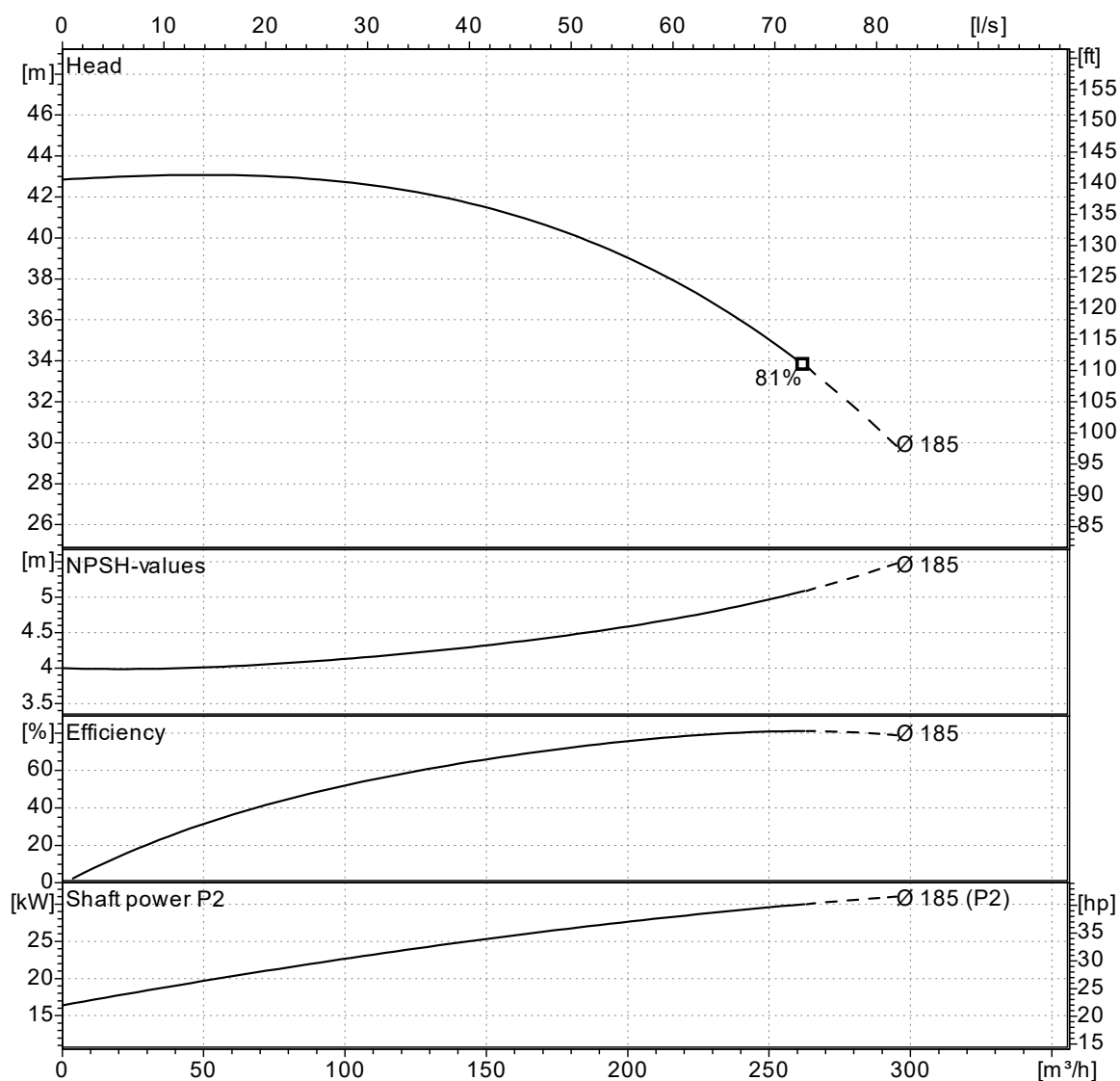

Curves compatible with ISO 9906:2012 Gr 3B

NPSHa > NPSHr + 1m

Note : The motor power is not sufficient for dotted area.

Company		Date	31/01/2023
Project		Item	
		Ref No.	

SNSM 100-200-30

Horizontal, single stage, radially split, closed-coupled, volute casing type conforming to EN 733 and EU 547/2012

Pump Dimensions

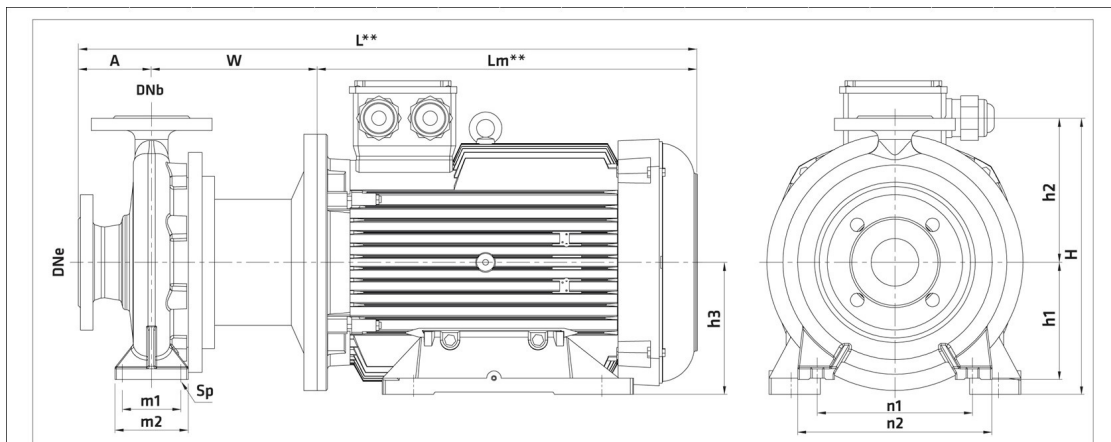

** Ölçüler motor üreticisine göre değişiklik gösterebilir. / ** Differs according to motor manufacturer.

3000 rpm																	
	Motor			(mm)													
	kW	IEC	DNe	DNb	A	W	Lm**	L**	H	h1	h2	h3	m1	m2	n1	n2	Sp
100-200	30	200L	125	100	125	246	555	926	480	200	280	200	120	160	280	360	19
100-200	37	200L	125	100	125	246	555	926	480	200	280	200	120	160	280	360	19
100-200	45	225M	125	100	125	248	625	998	505	200	280	225	120	160	280	360	19
100-200	55	250M	125	100	125	294	754	1173	530	200	280	250	120	160	280	360	19
1500 rpm																	
	Motor			(mm)													
	kW	IEC	DNe	DNb	A	W	Lm**	L**	H	h1	h2	h3	m1	m2	n1	n2	Sp
100-200	4	112M	125	100	125	189	336	650	480	200	280	112	120	160	280	360	19
100-200	5,5	132M	125	100	125	214	396	735	480	200	280	132	120	160	280	360	19
100-200	7,5	132M	125	100	125	214	396	735	480	200	280	132	120	160	280	360	19

Flange Dimensions



Suction Flange

AB = 125
Df = 250
k = 210
n = 8
s = 19

Discharge Flange

AB = 100
Df = 220
k = 180
n = 8
s = 19

" n " number of holes

Company		Date	31/01/2023
Project		Item	
		Ref No.	

SNSM 100-200-30

Horizontal, single stage, radially split, closed-coupled, volute casing type conforming to EN 733 and EU 547/2012

Motor Data

Efficiency Level : -

Motor type : Three-Phase Asynchronous Motor

Motor Power : 30.0 kW

Rated Speed : 2950 rpm

Voltage : 380 V

Rated Current : 0.00 A

Frequency : 50 Hz

Motor Phase : 3

Service Factor : 1.15

Insulation Class : F

Degree of Protection : IP 55

Efficiency : - %

Power factor : 0.00