

Product description

MN75E80-200-2P-50-TM-SS

Pos.no	Description	Item no	Qty.	UP / €	TP / €
1	Close-coupled electric pump according to EN 733 (DIN 24255)				
2	Centrifugal pump: MN75E80-200-2P-50-TM-SS		1	Price on req.	Price on req.
3	<p>Pump bodies</p> <p>Close-coupled electric pumps in compliance with EN 733 - DIN 24255 standards coupled to IEC standard electric motors through rigid coupling.</p> <p>Duty point Flow : / Head :</p> <p>Pump operating data Impeller diameter : 218 mm / Speed : 2.900 1/min Flow : / Head : Shaft power P2 : / Efficiency : Head (Q = 0) : 70,07 m</p> <p>Pump body : Cast iron Impeller : Stainless steel Wear ring : Cast iron Support : Cast iron Coupling : Cast iron Shaft : Stainless steel</p> <p>Max. solid contents : 40 g/m³ Max. water temperature : 90 °C Max. running time with Q=0 : 2 min</p>				
4	Motor: IEC 75 - 2		1		
5	<p>Electric motor</p> <p>Three-phase IE3 asynchronous squirrel cage motor.</p> <p>Casing : Cast iron</p> <p>Protection : IP 55 Insulation class : F Number of startings : max 4 Max environment temperature : 40 °C Max altimetric level : 1000 m Weight : 426 kg</p> <p>Frequency : 50 Hz N. poles : 2 P2 : 55 kW U : 400 V In 1/1 : 94,6 A EFF : 94,3 % CosPhi : 0,89</p>				
6	Shaft seal: Mechanical seal		1		
7	<p>Cover : Cast iron</p> <p>Spacer : Stainless steel</p> <p>Seal face : Graphite</p> <p>Seat : Ceramic</p> <p>Seal ring : NBR</p> <p>Spring : AISI 304 stainless steel</p>				

Technical data

MN75E80-200-2P-50-TM-SS

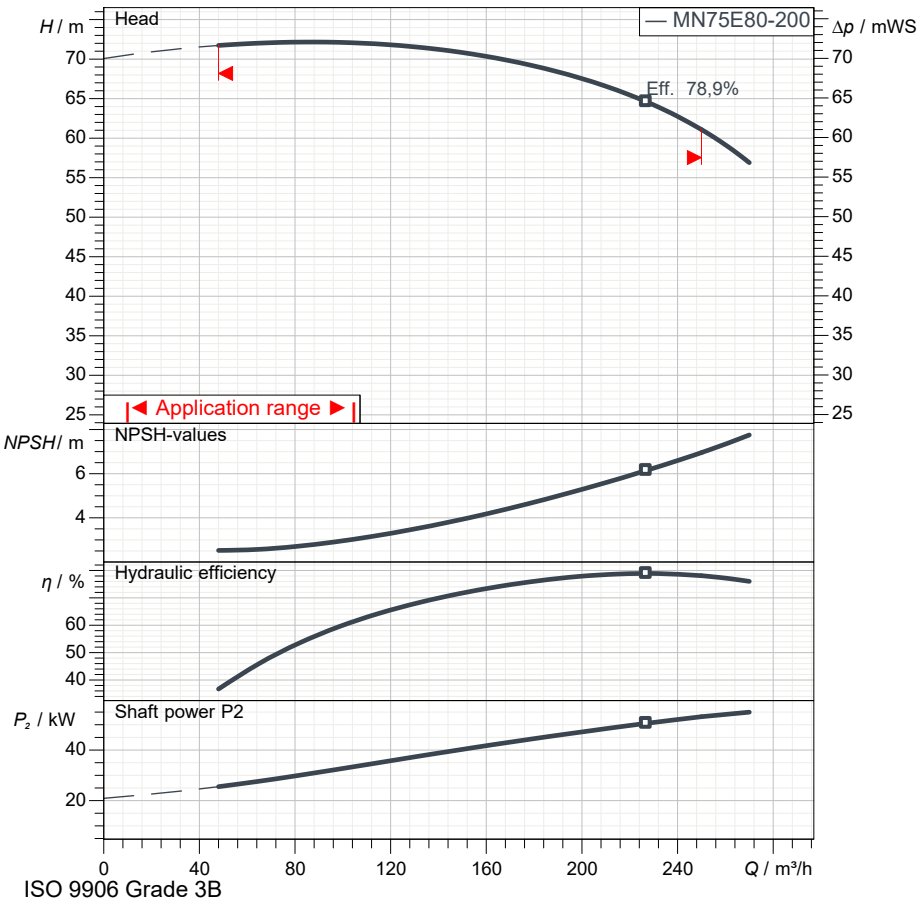

Operating data specification	
Capacity	
Head	
Fluid	Pure water
Type of installation	<Single head pump>

Pump operating data	
Design	MN75E80-200-2P-50-TM-SS
Impeller Ø	218 mm
Speed	2.900 1/min
Flow	
Head	
Shaft power P2	
Efficiency	
Head (Q=0)	70,1 m
Non return valve loss	

Electric motor technical data	
Design	IEC 75 - 2
Rated power	55 kW
Frequency	50 Hz
Number of poles	2
Nominal speed	2.900 1/min
Rated voltage	3~ 400 V
Starting mode	Direct starting
Rated current	94,6 A
Insulation class	F
Degree of protection	IP 55

Use limits	
Max N° startings/hour	4
Max. running time with Q=0	2 min
Max. solids contents	40 g/m ³
Max. pumped liquid temperature	90 °C
Maximum density	998 kg/m ³
Maximum viscosity	1 mm ² /s

Materials	
Pump body	Cast iron
Impeller	Stainless steel
Wear ring	Cast iron
Support	Cast iron
Coupling	Cast iron
Shaft	Stainless steel

Shaft seal	
Cover	Cast iron
Spacer	Stainless steel
Seal face	Graphite
Seat	Ceramic
Seal ring	NBR
Spring	AISI 304 stainless steel

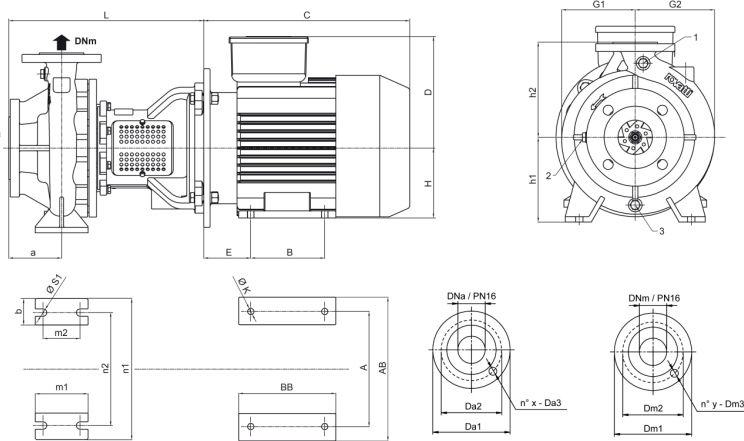

Dimensions in mm				Total weight				514 kg	
a	125	Da1	220	E	168	m1	125		
A	406	Da2	180	G1	163	m2	95		
AB	485	Da3	18	G2	188	n1	345		
b	65	Dm1	200	H	250	n2	280		
B	349	Dm2	160	h1	180	s1	14		
BB	445	Dm3	18	h2	250	x	8		
C	770	DNa	100	K	24	y	8		
D	375	DNrr	80	L	487				

Performance curves

MN75E80-200-2P-50-TM-SS

Performances				
Speed		2.900 1/min	Density	998 kg/m ³
Flow	Min.	48 m ³ /h	Viscosity	1 mm ² /s
	Max.	250 m ³ /h	Temperature	20 °C
Efficiency	Max.	227 m ³ /h	Tolerances	ISO 9906 Grade 3B

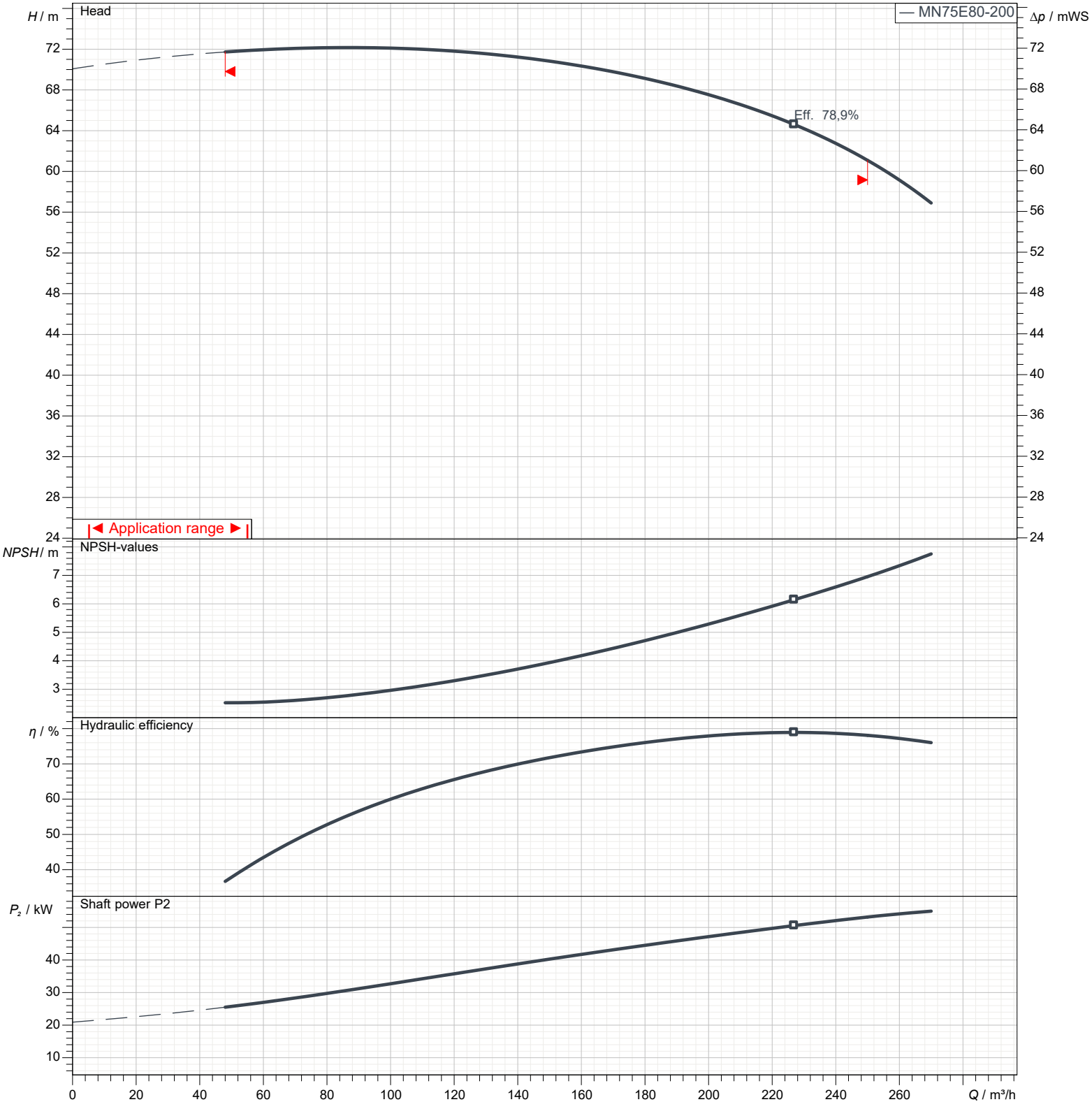

Types of installation

MN75E80-200-2P-50-TM-SS



Total weight		514 kg		Dimensions in mm	
a	125	h2	250		
A	406	K	24		
AB	485	L	487		
b	65	m1	125		
B	349	m2	95		
BB	445	n1	345		
C	770	n2	280		
D	375	s1	14		
Da1	220	x	8		
Da2	180	y	8		
Da3	18				
Dm1	200				
Dm2	160				
Dm3	18				
DNa	100				
DNm	80				
E	168				
G1	163				
G2	188				
H	250				
h1	180				