

## Product description

### MN15E100-250-4P-50-TM-SS

Pos.no	Description	Item no	Qty.	UP / €	TP / €
1	<b>Close-coupled electric pump according to EN 733 (DIN 24255)</b>				
2	Centrifugal pump: MN15E100-250-4P-50-TM-SS		1	Price on req.	Price on req.
3	<p>Pump bodies</p> <p>Close-coupled electric pumps in compliance with EN 733 - DIN 24255 standards coupled to IEC standard electric motors through rigid coupling.</p> <p>Duty point</p> <p>Flow : / Head :</p> <p>Pump operating data</p> <p>Impeller diameter : 246 mm / Speed : 1.450 1/min</p> <p>Flow : / Head :</p> <p>Shaft power P2 : / Efficiency :</p> <p>Head (Q = 0) : 21,96 m</p> <p>Pump body : Cast iron</p> <p>Impeller : Stainless steel</p> <p>Wear ring : Cast iron</p> <p>Support : Cast iron</p> <p>Coupling : Cast iron</p> <p>Shaft : Stainless steel</p> <p>Max. solid contents : 40 g/m<sup>3</sup></p> <p>Max. water temperature : 90 °C</p> <p>Max. running time with Q=0 : 2 min</p>				
4	Motor: IEC 15 - 4		1		
5	<p>Electric motor</p> <p>Three-phase IE3 asynchronous squirrel cage motor.</p> <p>Casing : Cast iron</p> <p>Protection : IP 55</p> <p>Insulation class : F</p> <p>Number of startings : max 14</p> <p>Max environment temperature : 40 °C</p> <p>Max altimetric level : 1000 m</p> <p>Weight : 123 kg</p> <p>Frequency : 50 Hz</p> <p>N. poles : 4</p> <p>P2 : 11 kW</p> <p>U : 400 V</p> <p>In 1/1 : 20,4 A</p> <p>EFF : 91,4 %</p> <p>CosPhi : 0,85</p>				
6	Shaft seal: Mechanical seal		1		
7	<p>Cover : Cast iron</p> <p>Spacer : Stainless steel</p> <p>Seal face : Graphite</p> <p>Seat : Ceramic</p> <p>Seal ring : NBR</p> <p>Spring : AISI 304 stainless steel</p>				

## Technical data

### MN15E100-250-4P-50-TM-SS

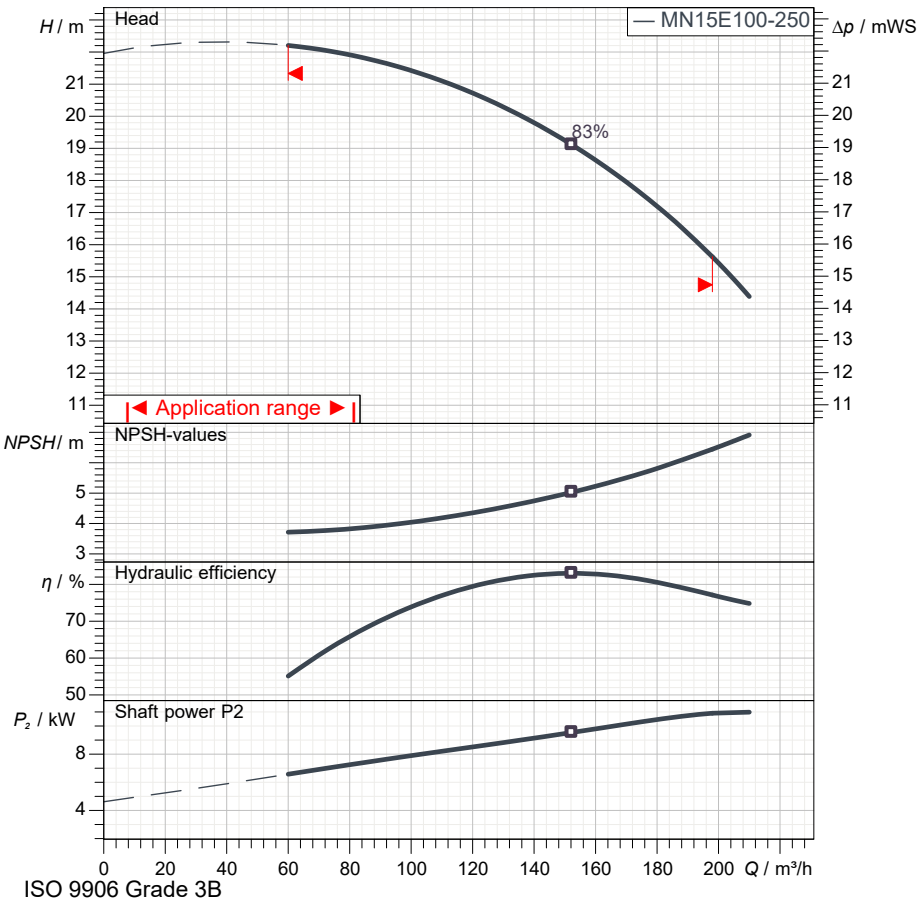

Operating data specification	
Capacity	
Head	
Fluid	Pure water
Type of installation	<Single head pump>

Pump operating data	
Design	MN15E100-250-4P-50-TM-S
Impeller $\varnothing$	246 mm
Speed	1.450 1/min
Flow	
Head	
Shaft power $P_2$	
Efficiency	
Head ( $Q=0$ )	22 m
Non return valve loss	

Electric motor technical data	
Design	IEC 15 - 4
Rated power	11 kW
Frequency	50 Hz
Number of poles	4
Nominal speed	1.450 1/min
Rated voltage	3~ 400 V
Starting mode	Direct starting
Rated current	20,4 A
Insulation class	F
Degree of protection	IP 55

Use limits	
Max N° startings/hour	14
Max. running time with $Q=0$	2 min
Max. solids contents	40 $g/m^3$
Max. pumped liquid temperature	90 °C
Maximum density	998 $kg/m^3$
Maximum viscosity	1 $mm^2/s$

Materials	
Pump body	Cast iron
Impeller	Stainless steel
Wear ring	Cast iron
Support	Cast iron
Coupling	Cast iron
Shaft	Stainless steel

Shaft seal	
Cover	Cast iron
Spacer	Stainless steel
Seal face	Graphite
Seat	Ceramic
Seal ring	NBR
Spring	AISI 304 stainless steel

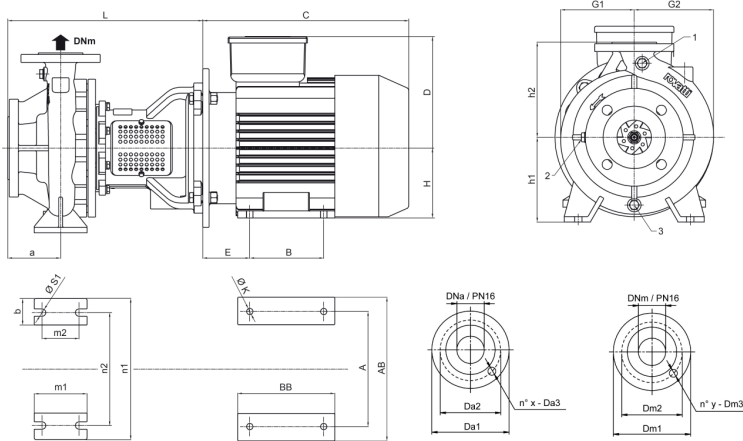

Dimensions in mm					Total weight			217 kg
a	140	Da3	18	G2	223	n1	400	
A	254	Dm1	220	H	160	n2	315	
AB	315	Dm2	180	h1	225	s1	19	
b	80	Dm3	18	h2	280	x	8	
B	210	DNa	125	K	15	y	8	
BB	260	DNrr	100	L	472			
Da1	250	E	108	m1	160			
Da2	210	G1	192	m2	120			

## Performance curves

### MN15E100-250-4P-50-TM-SS

Performances				
Speed		1.450 1/min	Density	998 kg/m <sup>3</sup>
Flow	Min.	60 m <sup>3</sup> /h	Viscosity	1 mm <sup>2</sup> /s
	Max.	198 m <sup>3</sup> /h	Temperature	20 °C
Efficiency	Max.	152 m <sup>3</sup> /h	Tolerances	ISO 9906 Grade 3B

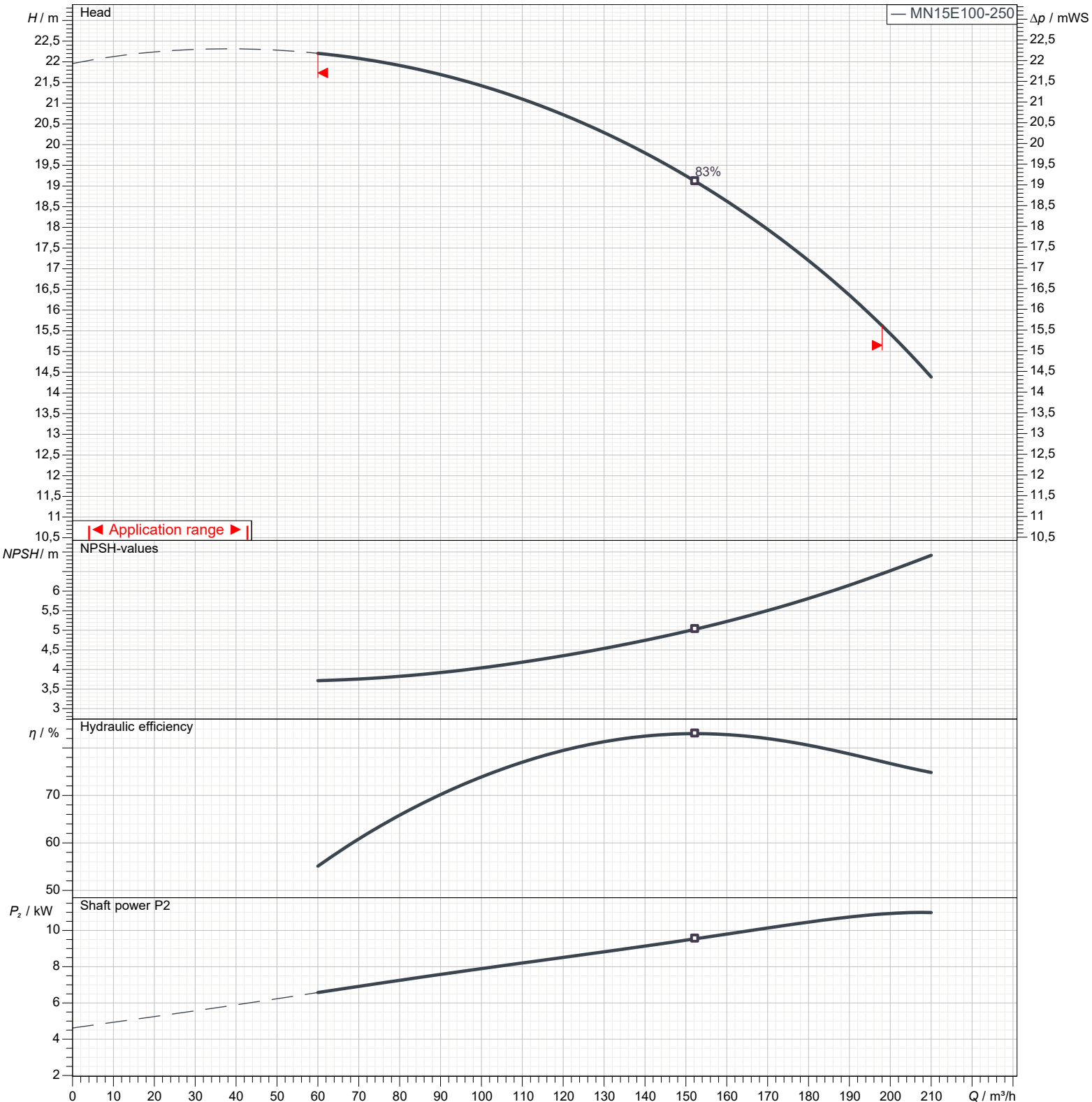

## Types of installation

### MN15E100-250-4P-50-TM-SS



Total weight		217 kg		Dimensions in mm	
a	140	L	472		
A	254	m1	160		
AB	315	m2	120		
b	80	n1	400		
B	210	n2	315		
BB	260	s1	19		
Da1	250	x	8		
Da2	210	y	8		
Da3	18				
Dm1	220				
Dm2	180				
Dm3	18				
DNa	125				
DNm	100				
E	108				
G1	192				
G2	223				
H	160				
h1	225				
h2	280				
K	15				